



Designation: D97 – 16



Designation: 15/95

## Standard Test Method for Pour Point of Petroleum Products<sup>1</sup>

This standard is issued under the fixed designation D97; the number immediately following the designation indicates the year of original adoption or, in the case of revision, the year of last revision. A number in parentheses indicates the year of last reapproval. A superscript epsilon ( $\epsilon$ ) indicates an editorial change since the last revision or reapproval.

*This standard has been approved for use by agencies of the U.S. Department of Defense.*

### 1. Scope\*

1.1 This test method covers and is intended for use on any petroleum product.<sup>2</sup> A procedure suitable for black specimens, cylinder stock, and nondistillate fuel oil is described in 8.8. The cloud point procedure formerly part of this test method now appears as Test Method **D2500**.

1.2 Currently there is no ASTM test method for automated Test Method D97 pour point measurements.

1.3 Several ASTM test methods offering alternative procedures for determining pour points using automatic apparatus are available. None of them share the same designation number as Test Method D97. When an automatic instrument is used, the ASTM test method designation number specific to the technique shall be reported with the results. A procedure for testing the pour point of crude oils is described in Test Method **D5853**.

1.4 The values stated in SI units are to be regarded as standard. No other units of measurement are included in this standard.

1.5 **WARNING**—Mercury has been designated by many regulatory agencies as a hazardous material that can cause central nervous system, kidney and liver damage. Mercury, or its vapor, may be hazardous to health and corrosive to materials. Caution should be taken when handling mercury and mercury containing products. See the applicable product Material Safety Data Sheet (MSDS) for details and EPA's website—<http://www.epa.gov/mercury/faq.htm>—for additional information. Users should be aware that selling mercury and/or mercury containing products into your state or country may be prohibited by law.

<sup>1</sup> This test method is under the jurisdiction of ASTM Committee **D02** on Petroleum Products, Liquid Fuels, and Lubricants and is the direct responsibility of Subcommittee **D02.07** on Flow Properties.

Current edition approved Jan. 1, 2016. Published February 2016. Originally approved in 1927, replacing D47. Last previous edition approved in 2015 as D97 – 15. DOI: 10.1520/D0097-16.

In the IP, this test method is under the jurisdiction of the Standardization Committee. This test method was adopted as a joint ASTM-IP Standard in 1965.

<sup>2</sup> Statements defining this test and its significance when applied to electrical insulating oils of mineral origin will be found in Guide **D117**.

1.6 *This standard does not purport to address all of the safety concerns, if any, associated with its use. It is the responsibility of the user of this standard to establish appropriate safety and health practices and determine the applicability of regulatory limitations prior to use.*

### 2. Referenced Documents

#### 2.1 ASTM Standards:<sup>3</sup>

**D117** Guide for Sampling, Test Methods, and Specifications for Electrical Insulating Oils of Petroleum Origin

**D396** Specification for Fuel Oils

**D2500** Test Method for Cloud Point of Petroleum Products

**D5853** Test Method for Pour Point of Crude Oils

**D6300** Practice for Determination of Precision and Bias Data for Use in Test Methods for Petroleum Products and Lubricants

**D7962** Practice for Determination of Minimum Immersion Depth and Assessment of Temperature Sensor Measurement Drift

**E1** Specification for ASTM Liquid-in-Glass Thermometers

**E644** Test Methods for Testing Industrial Resistance Thermometers

**E1137** Specification for Industrial Platinum Resistance Thermometers

**E2877** Guide for Digital Contact Thermometers

#### 2.2 Energy Institute Standards:<sup>4</sup>

**Specifications for IP Standard Thermometers**

### 3. Terminology

#### 3.1 Definitions:

3.1.1 *black oil, n*—lubricant containing asphaltic materials. Black oils are used in heavy-duty equipment applications, such as mining and quarrying, where extra adhesiveness is desired.

<sup>3</sup> For referenced ASTM standards, visit the ASTM website, [www.astm.org](http://www.astm.org), or contact ASTM Customer Service at [service@astm.org](mailto:service@astm.org). For *Annual Book of ASTM Standards* volume information, refer to the standard's Document Summary page on the ASTM website.

<sup>4</sup> Available from Energy Institute, 61 New Cavendish St., London, W1G 7AR, U.K., <http://www.energyinst.org>.

\*A Summary of Changes section appears at the end of this standard

3.1.2 *cylinder stock, n*—lubricant for independently lubricated engine cylinders, such as those of steam engines and air compressors. Cylinder stock are also used for lubrication of valves and other elements in the cylinder area.

3.1.3 *digital contact thermometer (DCT), n*—an electronic device consisting of a digital display and associated temperature sensing probe.

3.1.3.1 *Discussion*—This device consists of a temperature sensor connected to a measuring instrument; this instrument measures the temperature-dependent quantity of the sensor, computes the temperature from the measured quantity, and provides a digital output. This digital output goes to a digital display and/or recording device that may be internal or external to the device. These devices are sometimes referred to as a “digital thermometer”.

3.1.3.2 *Discussion*—Portable electronic thermometers (PET) is an acronym sometimes used to refer to a subset of the devices covered by this definition.

3.1.4 *pour point, n*—in petroleum products, the lowest temperature at which movement of the test specimen is observed under prescribed conditions of test.

3.1.5 *residual fuel, n*—a liquid fuel containing bottoms remaining from crude distillation or thermal cracking; sometimes referred to as heavy fuel oil.

3.1.5.1 *Discussion*—Residual fuels comprise Grades 4, 5, and 6 fuel oils, as defined in Specification D396.

4. Summary of Test Method

4.1 After preliminary heating, the sample is cooled at a specified rate and examined at intervals of 3 °C for flow characteristics. The lowest temperature at which movement of the specimen is observed is recorded as the pour point.

5. Significance and Use

5.1 The pour point of a petroleum specimen is an index of the lowest temperature of its utility for certain applications.

6. Apparatus

6.1 *Test Jar*, cylindrical, of clear glass, flat bottom, 33.2 mm to 34.8 mm outside diameter, and 115 mm to 125 mm in height. The inside diameter of the jar can range from 30.0 mm to 32.4 mm, within the constraint that the wall thickness be no greater than 1.6 mm. The jar shall have a line to indicate a sample height 54 mm ± 3 mm above the inside bottom. See Fig. 1.

6.2 *Temperature Measuring Device*—Either liquid-in-glass thermometer as described in 6.2.1 or Digital Contact Thermometer (DCT) meeting the requirements described in 6.2.2.<sup>5</sup>

<sup>5</sup> Supporting data have been filed at ASTM International Headquarters and may be obtained by requesting Research Report RR:D02-1826. Contact ASTM Customer Service at service@astm.org.

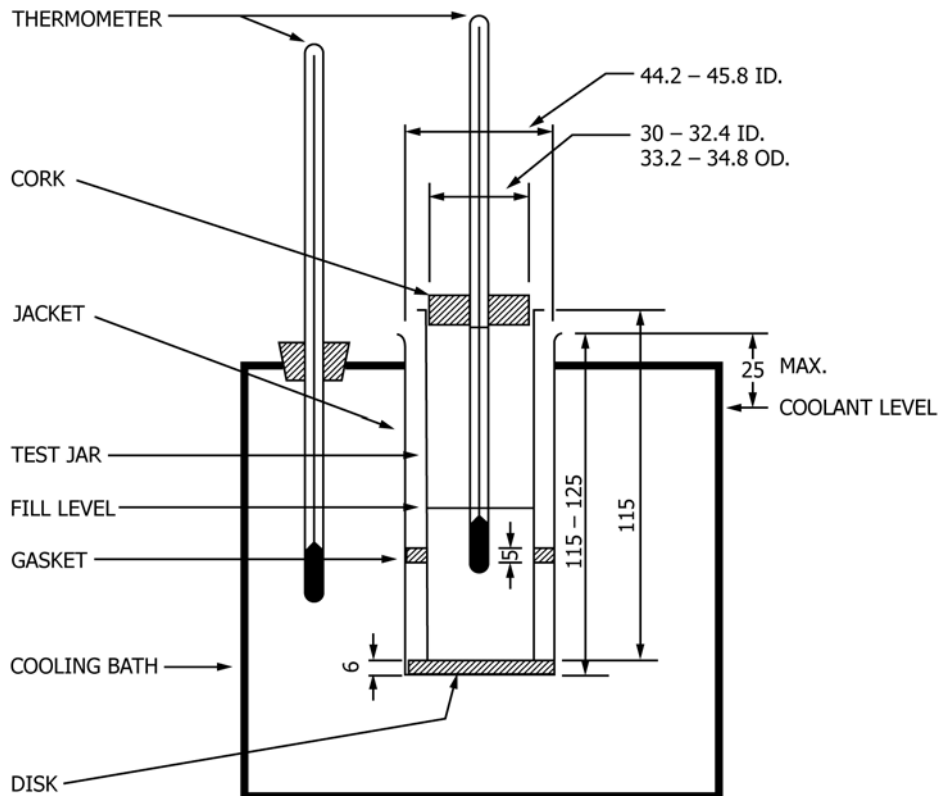

NOTE 1—Dimensions are in millimetres (not to scale).

FIG. 1 Apparatus for Pour Point Test

6.2.1 *Liquid-in-Glass Thermometers*, having the following ranges and conforming to the requirements prescribed in Specification **E1** or Specifications for IP Standard Thermometers:

| Thermometer         | Temperature       | Thermometer Number |     |
|---------------------|-------------------|--------------------|-----|
|                     | Range             | ASTM               | IP  |
| High cloud and pour | -38 °C to +50 °C  | 5C                 | 1C  |
| Low cloud and pour  | -80 °C to +20 °C  | 6C                 | 2C  |
| Melting point       | +32 °C to +127 °C | 61C                | 63C |

6.2.1.1 Since separation of liquid column thermometers occasionally occurs and may escape detection, thermometers should be checked immediately prior to the test and used only if they prove accurate within  $\pm 1$  °C (for example ice point).

#### 6.2.2 *Digital Contact Thermometer Requirements:*

| Parameter              | Requirement   |
|------------------------|---|
| DCT                    | Guide <b>E2877</b> Class G or better  |
| Temperature range      | -65 °C to 90 °C   |
| Display resolution     | 1 °C minimum, preferably 0.1 °C   |
| Sensor type            | PRT, thermistor, thermocouple   |
| Sensor                 | 3 mm OD sheath with a sensing element less than 10 mm in length   |
| Minimum immersion      | Less than 40 mm per Test Method <b>D7962</b>  |
| Sample immersion depth | Between 10 mm and 15 mm in the sample.<br><b>Fig. 1</b>   |
| Display accuracy       | $\pm 500$ mK ( $\pm 0.5$ °C) for combined probe and sensor  |
| Response time          | less than or equal to 25 s as defined in Specification <b>E1137</b>   |
| Drift                  | less than 500 mK (0.5 °C) per year  |
| Calibration error      | less than 500 mK (0.5 °C) over the range of intended use.   |
| Calibration range      | -40 °C or lower to 85 °C  |
| Calibration data       | 4 data points evenly distributed over calibration range with data included in calibration report.   |
| Calibration report     | From a calibration laboratory with demonstrated competency in temperature calibration which is traceable to a national calibration laboratory or metrology standards body |

NOTE 1—When the DCT display is mounted on the end to the probe's sheath, the test jar with the probe inserted will be unstable. To resolve this, it is recommended that the probe be less than 30 cm in length but no less

than 15 cm. A 5 cm long stopper, that has a low thermal conductivity, with approximately half of it inserted in the sample tube will improve stability.

6.2.2.1 The DCT calibration drift shall be checked at least annually by either measuring the ice point or against a reference thermometer in a constant temperature bath at the prescribed immersion depth to ensure compliance with **6.2.2**. See Test Method **D7962**.

NOTE 2—When a DCT's calibration drifts in one direction over several calibration checks, that is, ice point, it may be an indication of deterioration of the DCT.

6.3 *Cork*, to fit the test jar, bored centrally for the test thermometer.

6.4 *Jacket*, watertight, cylindrical, metal, flat-bottomed, 115 mm  $\pm$  3 mm depth, with inside diameter of 44.2 mm to 45.8 mm. It shall be supported in a vertical position in the cooling bath (see **6.7**) so that not more than 25 mm projects out of the cooling medium, and shall be capable of being cleaned.

6.5 *Disk*, cork or felt, 6 mm thick to fit loosely inside the jacket.

6.6 *Gasket Ring Form*, about 5 mm in thickness, to fit snugly around the outside of the test jar and loosely inside the jacket. The gasket may be made of rubber, leather, or other material that is elastic enough to cling to the test jar and hard enough to hold its shape. Its purpose is to prevent the test jar from touching the jacket.

6.7 *Bath or Baths*, maintained at prescribed temperatures with a firm support to hold the jacket vertical. The required bath temperatures may be obtained by refrigeration if available, otherwise by suitable cooling mixtures. Cooling mixtures commonly used for bath temperatures down to those shown are in **Table 1**.

## 7. Reagents and Materials

7.1 The following solvents of technical grade are appropriate for low-temperature bath media.

7.1.1 *Acetone*, (**Warning**—Extremely flammable).

7.1.2 *Alcohol, Ethanol* (**Warning**—Flammable).

7.1.3 *Alcohol, Methanol* (**Warning**—Flammable. Vapor harmful).

7.1.4 *Petroleum Naphtha*, (**Warning**—Combustible. Vapor harmful).

7.1.5 *Solid Carbon Dioxide*, (**Warning**—Extremely cold -78.5 °C).

**TABLE 1 Cooling Mixtures and Bath Temperatures**

| Cooling Mixture  | Bath Temperature |
|--|------------------|
| Ice and water  | 0 °C ± 1.5 °C    |
| Crushed ice and sodium chloride crystals or Acetone or petroleum naphtha, or methanol or ethanol (see Section 7) with solid carbon dioxide added to give the desired temperature | -18 °C ± 1.5 °C  |
| Acetone or petroleum naphtha or methanol or ethanol (see Section 7) with solid carbon dioxide added to give the desired temperature  | -33 °C ± 1.5 °C  |
| Acetone or petroleum naphtha or methanol or ethanol (see Section 7) with solid carbon dioxide added to give the desired temperature  | -51 °C ± 1.5 °C  |
| Acetone or petroleum naphtha or methanol or ethanol (see Section 7) with solid carbon dioxide added to give the desired temperature  | -69 °C ± 1.5 °C  |

## 8. Procedure

8.1 Pour the specimen into the test jar to the level mark. When necessary, heat the specimen in a bath until it is just sufficiently fluid to pour into the test jar.

NOTE 3—It is known that some materials, when heated to a temperature higher than 45 °C during the preceding 24 h, do not yield the same pour point results as when they are kept at room temperature for 24 h prior to testing. Examples of materials which are known to show sensitivity to thermal history are residual fuels, black oils, and cylinder stocks.

8.1.1 Samples of residual fuels, black oils, and cylinder stocks which have been heated to a temperature higher than 45 °C during the preceding 24 h, or when the thermal history of these sample types is not known, shall be kept at room temperature for 24 h before testing. Samples which are known by the operator not to be sensitive to thermal history need not be kept at room temperature for 24 h before testing.

8.1.2 Experimental evidence supporting elimination of the 24 h waiting period for some sample types is contained in a research report.<sup>6</sup>

8.2 In the case of pour points above 36 °C, use a higher range thermometer such as IP 63C or ASTM 61C. Close the test jar with the cork carrying the test thermometer (6.2). Adjust the position of the cork and thermometer so the cork fits tightly, the thermometer and the jar are coaxial, and the thermometer is immersed to the correct depth. For liquid-in-glass, the thermometer bulb should be immersed so the beginning of the capillary is 3 mm below the surface of the specimen. For digital contact thermometers, the probe should be immersed so the end of the probe is 10 mm to 15 mm below the surface of the specimen.

8.3 For the measurement of pour point, subject the specimen in the test jar to the following preliminary treatment:

8.3.1 *Specimens Having Pour Points Above -33 °C*—Heat the specimen without stirring to 9 °C above the expected pour point, but to at least 45 °C, in a bath maintained at 12 °C above the expected pour point, but at least 48 °C. Transfer the test jar

to a bath maintained at 24 °C ± 1.5 °C and commence observations for pour point. When using a liquid bath, ensure that the liquid level is between the fill mark on the test jar and the top of the test jar.

8.3.2 *Specimens Having Pour Points of -33 °C and Below*—Heat the specimen without stirring to at least 45 °C in a bath maintained at 48 °C ± 1.5 °C. Transfer the test jar to a bath maintained at 24 °C ± 1.5 °C. When using a liquid bath, ensure that the liquid level is between the fill mark on the test jar and the top of the test jar. When the specimen temperature reaches 27 °C, remove the high cloud and pour thermometer, and place the low cloud and pour thermometer in position. Transfer the test jar to the cooling bath (see 8.6.1).

8.4 See that the disk, gasket, and the inside of the jacket are clean and dry. Place the disk in the bottom of the jacket. Place the gasket around the test jar, 25 mm from the bottom. Insert the test jar in the jacket. Never place a jar directly into the cooling medium.

8.5 After the specimen has cooled to allow the formation of paraffin wax crystals, take great care not to disturb the mass of specimen nor permit the thermometer to shift in the specimen; any disturbance of the spongy network of wax crystals will lead to low and erroneous results.

8.6 Pour points are expressed in integers that are positive or negative multiples of 3 °C. Begin to examine the appearance of the specimen when the temperature of the specimen is 9 °C above the expected pour point (estimated as a multiple of 3 °C). At each test thermometer reading that is a multiple of 3 °C below the starting temperature remove the test jar from the jacket. To remove condensed moisture that limits visibility wipe the surface with a clean cloth moistened in alcohol (ethanol or methanol). Tilt the jar just enough to ascertain whether there is a movement of the specimen in the test jar. If movement of specimen in the test jar is noted, then replace the test jar immediately in the jacket and repeat a test for flow at the next temperature, 3 °C lower. Typically, the complete operation of removal, wiping, and replacement shall require not more than 3 s.

<sup>6</sup> Supporting data have been filed at ASTM International Headquarters and may be obtained by requesting Research Report RR:D02-1377.

8.6.1 If the specimen has not ceased to flow when its temperature has reached 27 °C, transfer the test jar to a jacket in a cooling bath maintained at 0 °C ± 1.5 °C. As the specimen continues to get colder, transfer the test jar to a jacket in the next lower temperature cooling bath in accordance with [Table 2](#).

8.6.2 If the specimen in the jar does not show movement when tilted, hold the jar in a horizontal position for 5 s, as noted by an accurate timing device, and observe the specimen carefully. If the specimen shows any signs of movement before 5 s has passed, replace the test jar immediately in the jacket and repeat a test for flow at the next temperature, 3 °C lower.

8.7 Continue in this manner until a point is reached at which the specimen shows no movement when the test jar is held in a horizontal position for 5 s. Record the observed reading of the test thermometer.

8.8 For black specimen, cylinder stock, and nondistillate fuel specimen, the result obtained by the procedure described in [8.1](#) through [8.7](#) is the upper (maximum) pour point. If required, determine the lower (minimum) pour point by heating the sample while stirring, to 105 °C, pouring it into the jar, and determining the pour point as described in [8.4](#) through [8.7](#).

8.9 Some specifications allow for a pass/fail test or have pour point limits at temperatures not divisible by 3 °C. In these cases, it is acceptable practice to conduct the pour point measurement according to the following schedule: Begin to examine the appearance of the specimen when the temperature of the specimen is 9 °C above the specification pour point. Continue observations at 3 °C intervals as described in [8.6](#) and [8.7](#) until the specification temperature is reached. Report the sample as passing or failing the specification limit.

## 9. Calculation and Report

9.1 Add 3 °C to the temperature recorded in [8.7](#) and report the result as the Pour Point, ASTM D97. For black oil, and so forth, add 3 °C to the temperature recorded in [8.7](#) and report the result as Upper Pour Point, ASTM D97, or Lower Pour Point, ASTM D97, as required.

## 10. Precision and Bias

10.1 *Precision*—The precision of this test method as determined by the statistical examination of the interlaboratory test results is as follows:

NOTE 4—The precision statements were developed using liquid-in-glass thermometers corresponding to those in Specification [E1](#) or IP Specifications for IP Standard Thermometers.

**TABLE 2 Bath and Sample Temperature Ranges**

| Bath Temperature Setting, °C             | Sample Temperature Range, °C                          |
|--|---|
| 48 ± 1.5 or 12 above expected pour point | Preheat to at least 45 or 9 above expected pour point |
| 24 ± 1.5                                 | Start to 27   |
| 0 ± 1.5                                  | 27 to 9   |
| -18 ± 1.5                                | 9 to -6   |
| -33 ± 1.5                                | -6 to -24   |
| -51 ± 1.5                                | -24 to -42  |
| -69 ± 1.5                                | -42 to -60  |

### 10.1.1 *Lubricating Oil*:<sup>7</sup>

10.1.1.1 *Repeatability*—The difference between successive test results, obtained by the same operator using the same apparatus under constant operating conditions on identical test material would, in the long run, in the normal and correct operation of this test method, exceed 6 °C only in one case in twenty. Differences greater than this should be considered suspect.

10.1.1.2 *Reproducibility*—The difference between two single and independent test results, obtained by different operators working in different laboratories on identical test material would, in the long run, in the normal and correct operation of this test method, exceed 9 °C only in one case in twenty. Differences greater than this should be considered suspect.

10.1.1.3 The precision statements<sup>7</sup> were derived from a 1998 interlaboratory test program using Practice [D6300](#). Participants analyzed five sets of duplicate base oils, three sets of duplicate multigrade lubricating oils, and one set each of duplicate hydraulic oils and automatic transmission fluid in the temperature range of -51 °C to -11 °C. Seven laboratories participated with the manual Test Method D97. Information on the type of samples and their average pour points are in Research Report RR:D02-1499.<sup>7</sup>

NOTE 5—The precision statements are the derived values rounded up to the next testing interval value. The actual derived precision values appear in [Table X1.1](#).

### 10.1.2 *Middle Distillate and Residual Fuel*:<sup>8</sup>

10.1.2.1 *Repeatability*—The difference between successive test results obtained by the same operator using the same apparatus under constant operation conditions on identical test material would, in the long run, in the normal and correct operation of this test method, exceed 3 °C only in one case in twenty. Differences greater than this should be considered suspect.

10.1.2.2 *Reproducibility*—The difference between two single and independent test results, obtained by different operators working in different laboratories on identical test material would, in the long run, in the normal and correct operation of this test method, exceed 9 °C only in one case in twenty. Differences greater than this should be considered suspect.

10.1.2.3 The precision statements<sup>8</sup> were prepared with data on sixteen middle distillate and residual fuels tested by twelve cooperators. The fuels had pour points ranging from -33 °C to +51 °C.

NOTE 6—The precision statements are the derived values rounded up to the next testing interval value. The actual derived precision values can be seen in [Table X1.1](#).

NOTE 7—The precisions in [10.1.2](#) are not known to have been derived using Practice [D6300](#).

10.2 *Bias*—There being no criteria for measuring bias in these test-product combinations, no statement of bias can be made.

<sup>7</sup> Supporting data (the results of the 1998 interlaboratory cooperative test program) have been filed at ASTM International Headquarters and may be obtained by requesting Research Report RR:D02-1499.

<sup>8</sup> Based on the results of the 1983 interlaboratory cooperative test program.

## 11. Keywords

11.1 petroleum products; pour point

## APPENDIX

(Nonmandatory Information)

### X1. ACTUAL DERIVED PRECISION VALUES

X1.1 See [Table X1.1](#).

**TABLE X1.1 Actual Derived Precision Values**

| 95 % Confidence | 1998 Research Program<br>Lubricating Oil, °C | 1983 Research Program<br>Middle Distillate and<br>Residual Fuels, °C |
|-----------------|--|--|
| Repeatability   | 5.3  | 2.5  |
| Reproducibility | 8.0  | 6.6  |

### SUMMARY OF CHANGES

Subcommittee D02.07 has identified the location of selected changes to this standard since the last issue (D97 – 15) that may impact the use of this standard. (Approved Jan. 1, 2016.)

(1) Added new Research Report footnote<sup>5</sup> to [6.2](#).

Subcommittee D02.07 has identified the location of selected changes to this standard since the last issue (D97 – 12) that may impact the use of this standard. (Approved Oct. 1, 2015.)

(1) Revised [Section 2](#), [Section 3](#), subsection [6.2](#), and subsection [8.2](#).

*ASTM International takes no position respecting the validity of any patent rights asserted in connection with any item mentioned in this standard. Users of this standard are expressly advised that determination of the validity of any such patent rights, and the risk of infringement of such rights, are entirely their own responsibility.*

*This standard is subject to revision at any time by the responsible technical committee and must be reviewed every five years and if not revised, either reapproved or withdrawn. Your comments are invited either for revision of this standard or for additional standards and should be addressed to ASTM International Headquarters. Your comments will receive careful consideration at a meeting of the responsible technical committee, which you may attend. If you feel that your comments have not received a fair hearing you should make your views known to the ASTM Committee on Standards, at the address shown below.*

*This standard is copyrighted by ASTM International, 100 Barr Harbor Drive, PO Box C700, West Conshohocken, PA 19428-2959, United States. Individual reprints (single or multiple copies) of this standard may be obtained by contacting ASTM at the above address or at 610-832-9585 (phone), 610-832-9555 (fax), or [service@astm.org](mailto:service@astm.org) (e-mail); or through the ASTM website ([www.astm.org](http://www.astm.org)). Permission rights to photocopy the standard may also be secured from the Copyright Clearance Center, 222 Rosewood Drive, Danvers, MA 01923, Tel: (978) 646-2600; <http://www.copyright.com/>*